

# PIPE SPOOL FABRICATION

**Edmonton Exchanger**  
Pipe Fabrication Shop  
5325 93 Street NW  
Edmonton, Alberta

[www.edmontonexchanger.com](http://www.edmontonexchanger.com)





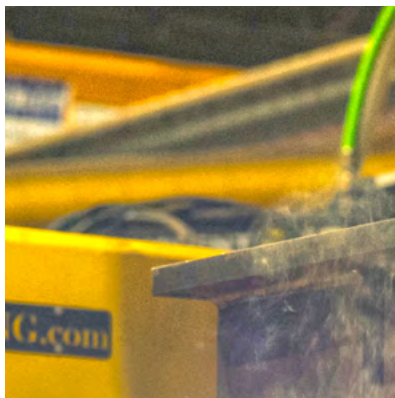

**CONTACT**

Steven Bohaychuk  
Pipe Fabrication Estimator / Project Coordinator  
Edmonton Exchanger Pipe Fabrication Shop  
5325 93 St. NW Edmonton  
Tel: 780 468 6722 ext. 406

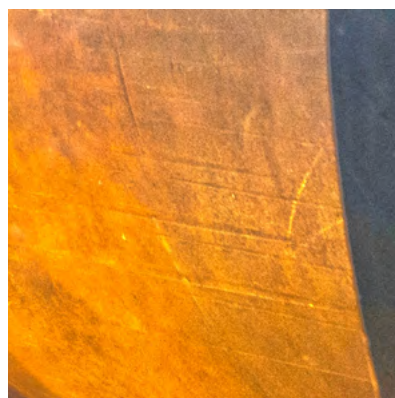
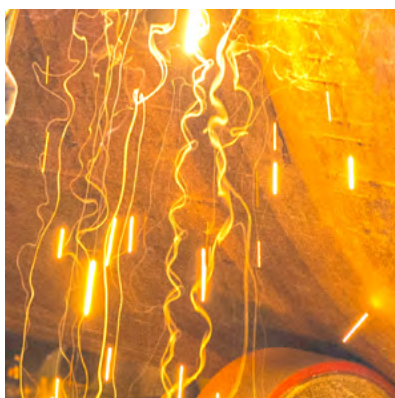
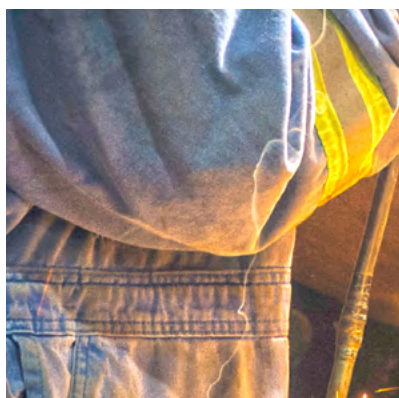

# PIPE SPOOL FABRICATION

Edmonton Exchanger’s pipe fabrication facility is located in close proximity to our main plant location, and constructs mechanical piping systems to ASME and client specifications.



## PIPE FABRICATION CAPABILITIES

Because we hold over 1,000 weld procedures, we have welded most materials required in Alberta. We can accommodate a wide variety of materials ranging from carbon steel, stainless steel, low alloys and high alloy materials.

### ABSA Fabrication Certification to Construct / Repair / Alter:

- ASME B31.1 Boiler External and Power Piping
- ASME B31.3 Process Piping, Direct Fired Heaters, and Indirect Fired Heating Coils
- ASME B31.9 Building Services Piping
- CSA Z662 Steam Pipelines
- ASME Section I Power Boilers and Direct Fired Heaters
- ASME Section VIII-1 Pressure Vessels
- ASME Section VIII-2 Pressure Vessels
- API 530 Direct Fired Heaters
- Category A, B, C, D, E, & H Fittings in accordance with CSA B51
- ASME Section IV Heating Boilers

### Additional Certifications:

- Services and products requiring CRNs – Alberta only and nationwide.
- CWB certified to CSA standard W47.1 for structural welding in Division 2
- ABSA Welder Testing

Once the project has been welded, our quality control staff who are CWB and CGSB qualified, perform LPI, MPI, Ferrite testing, hardness testing, PMI and UT. Edmonton Exchanger field crews can field measure and verify drawings before fabrication to minimize field work. We can also provide the field support to install the piping system, start the system with operations and then provide continuing maintenance on those systems.

## MANPOWER

Permanent Shop Labour: 15-30 (Allocated to Pipe Fabrication Division)

## KEY PERSONNEL

Name	Position	Years with Firm
Steven Bohaychuk	Piping Fabrication Estimator / Project Coordinator	2
Colin Molloy	Piping Fabrication Estimator / Project Coordinator	1
Tony Hallonquist	Pipe Shop Superintendent	13
Katherine Langevin	Pipe Fabrication Shop Quality Control	6
Devin Pearce	Pipe Fabrication Shop Quality Control	7
Wes Lakusta	Pipe Fabrication Shop Foreman	11
Tyler Rose	Pipe Fabrication Shop Foreman	7
Darrel Tranberg	Pipe Fabrication Shop Purchasing	13

# PIPE SPOOL FABRICATION

## CRNS

Edmonton Exchanger offers products and services with CRNs. New CRNs can be quoted, designed and built on request. Our in-house engineering and drafting team can handle any other custom requirements with ease and ensure ABSA compliance. We have a close relationship with ABSA because of our history of prudent designs.

Custom Valve modification project requiring a CRN:

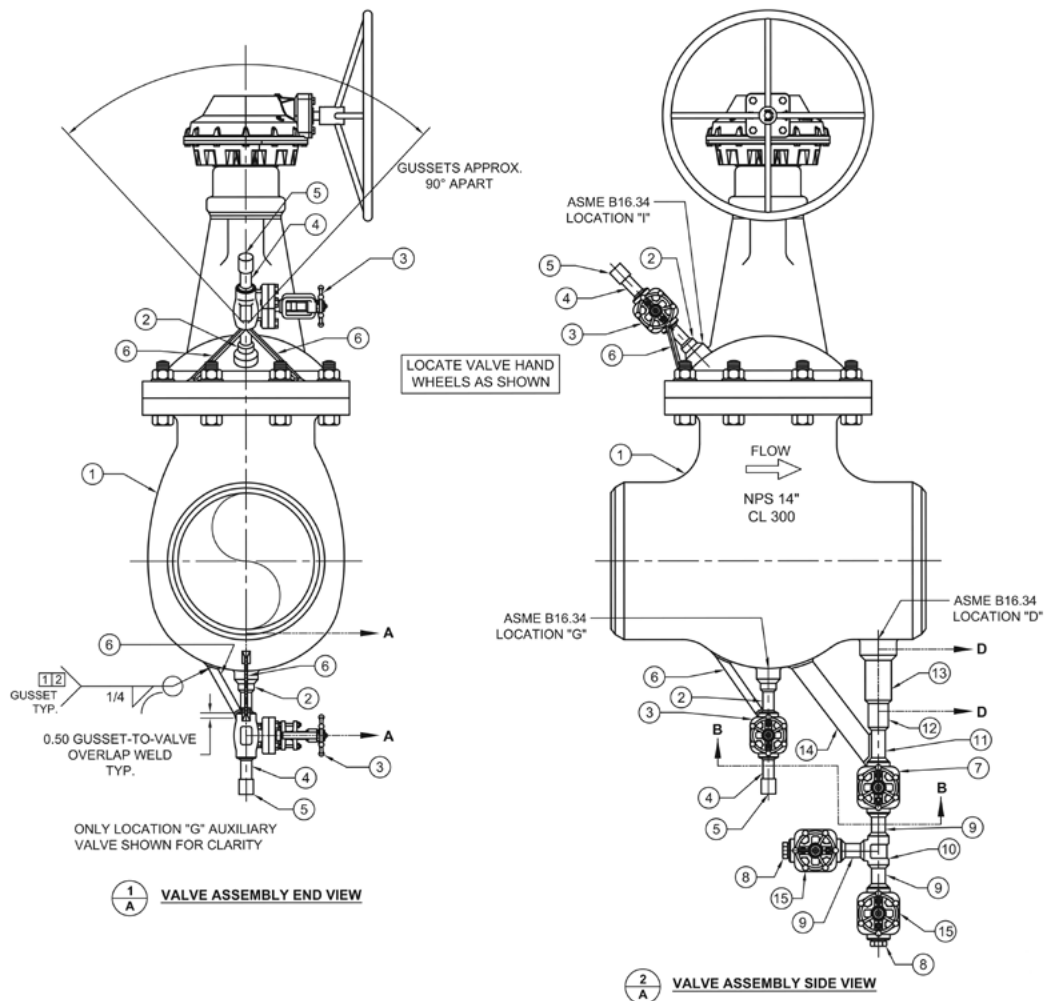



# PIPE SPOOL FABRICATION

## CRNS

- Edmonton Exchanger has the most comprehensive CRN for valve auxiliary connection modifications in Canada. The CRN covers a wide range of materials, valve sizes, valve ratings, gusseting requirements and the ability to build up valve bosses for under thickness valves.
- The CRN is registered in Alberta, with nation-wide registration being completed in the coming weeks. This CRN covers NPS 2" and larger valves that are rated CL150 to and including CL2500.
- Abbreviated List of Materials covered:
  - Carbon: regular WCB, WCC or low temp LF2, LCB, LCC
  - Chromes: P11, P22, P6, P9
  - Stainless steel: 304, 304H, 316, 317, 321, 321H, 347, 347H
  - Duplex SS: 2205
  - Monel 400, Inco 625 & 825, C22, C276, C2000, Alloy 20

**TABLE 8: ASME B16.34 VALVE BODY AUXILIARY CONNECTION BOSS LOCATIONS**

ANGLE VALVE	CHECK VALVE	GATE VALVE	GLOBE VALVE	BALL VALVE

**NOTES:**  
 1. LOCATIONS FOR VALVE BODY AUXILIARY CONNECTIONS SHALL BE DESIGNATED AS SHOWN  
 2. AUXILIARY CONNECTIONS TO BE DESCRIBED IN ACCORDANCE WITH SPEC.2

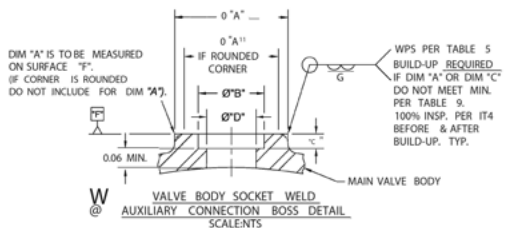

**TABLE 9: ASME B16.34 VALVE BODY AUXILIARY CONNECTION BOSS**

AUX CONN. NPS	BOSS DIA. "A" (MIN.)	SOCKET BORE "B" $\pm 0.010$ I -0.000	SOCKET DEPTH "C" (MIN.)	THRU HOLE "D" (SCH. 160)	THRU HOLE "D" (SCH. XXS)
1/2	1.50	0.855	0.19	7/16	1/4
3/4	1.75	1.065	0.25	5/8	7/16
1	2.13	1.330	0.25	13/16	19/32

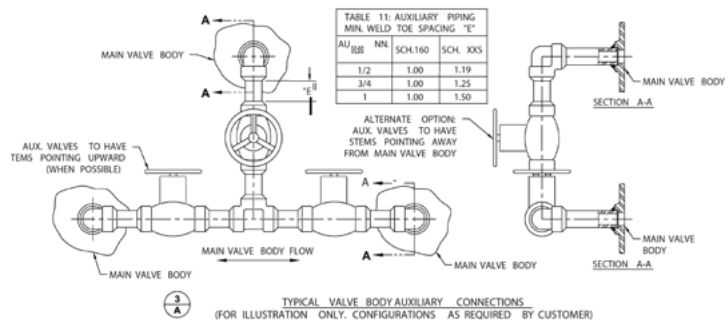

# PIPE SPOOL FABRICATION

## CRNS

- ABSA CRN Spectacle blinds, zero energy blinds, alky service vented blanks – all items with welded valves / gusseting attached.

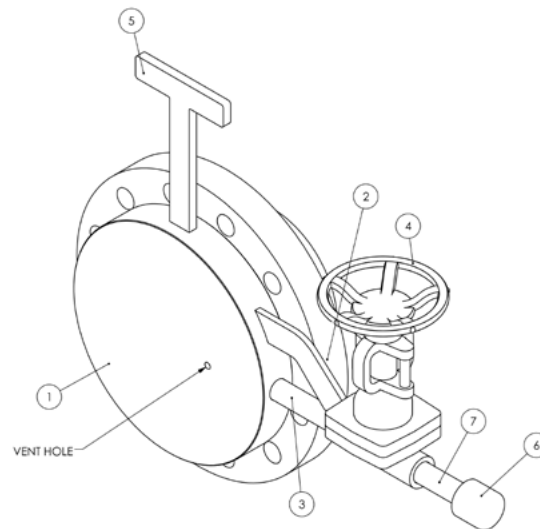

5 VENTED BLANK ASSEMBLY ISOMETRIC VIEW  
SCALE: DWG

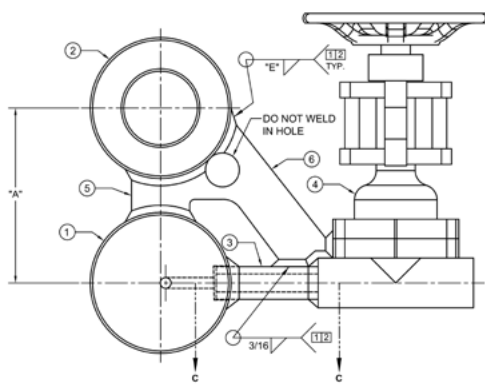

4 NPS 1-1/2" VENTED SPECTACLE  
BLIND ASSEMBLY DETAIL

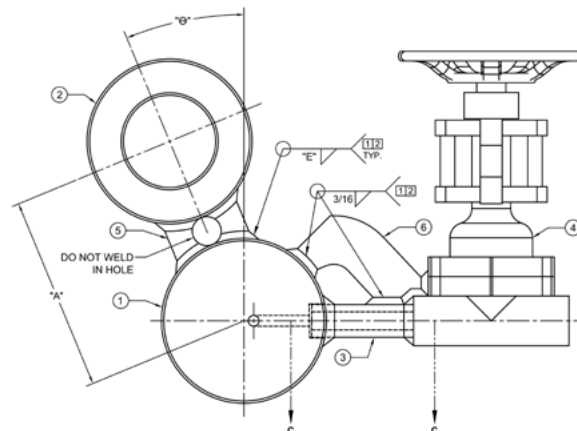

5 NPS 2" VENTED SPECTACLE BLIND  
ASSEMBLY DETAIL

# PIPE SPOOL FABRICATION

## OUR PROCESS

We work together with our Field Services team to ensure that what we build is correct to what the field requires. This minimizes / eliminates pipe spool rework. We take the information provided by the field to ensure that the plan can be built in accordance to client weld spacing / specifications, and fits inside the shipping envelope. If there are any issues, we try to identify them before the job has been put into fabrication. This ensures quick project turnaround times for the client.

When we receive a project to bid, we identify the materials that are required. If there are questions or errors on ISOs, we deal with them at the bid stage. This ensures that the work flows as smoothly and as quickly as possible once bids turn into jobs.



Once we are awarded a job, we get the ISO drawings turned into shop fabrication drawings. We provide ISOs marked up with our shop drawing numbers for easy field reference. We submit our shop drawings and the ISO map for field review and mark ups. Edmonton Exchanger reduces field rework by giving the field input into fabrication. The Pipe Fabrication Shop works closely with the Field Services division in determining priority of jobs and spool deliveries.

We have software which allows us to draft the fabrication drawings with Welder IDs, NDE performed, heat numbers of parts, weld procedures as well as to make any drawings changes required by the client. Drafting in-house enables us to quickly make drawing revisions with minimal downtime as the project scope changes. This software tracks material inventory and NDE percentages. All spools are provided with two plastic tags with the drawing information. These tags contain the fabrication drawing number, as well as the client isometric and project name for easy identification.

We order materials from reputable suppliers in accordance with client specifications and approved manufacturer lists.

All fabricated components undergo a thorough Quality Control inspection to ensure compliance to the applicable ASME code to which it has been constructed and all Jurisdictional requirements have been met. Our stringent QC program which also includes shop checking of all orientations and dimensions prior to shipment. All flanges are covered with plastic or wood flange covers prior to shipping.

# PIPE SPOOL FABRICATION

## MATERIALS MANAGEMENT

We are a maintenance spool fabrication provider. We are accustomed to delivering projects to tight deadlines. In spring 2018, we completed over 100 separate turnaround piping jobs in time for a spring turnaround. Supplying both the fabrication materials and field materials for all jobs. Jobs ranged in materials from low temperature carbon steel, to chrome and stainless steel. Over 20 different material / service classes.

We have sufficient storage space for both inventory materials for new fabrication and completed spools. Our North warehouse can be utilized as well in addition to our six acre yard. We have a comprehensive material management and receiving system that ensures the correct materials are used. We work with a wide range of materials including carbon steel, stainless, chrome, and high/low alloys.



## WELD PROCEDURES

Edmonton Exchanger has over 1,000 current weld procedures.

## SCOPE OF WORK AND ANNUAL DEMAND

The Edmonton Exchanger Pipe Fabrication Shop is familiar with maintenance piping projects for numerous clients.

In early 2017, our Pipe Fabrication Shop was sole sourced as the piping supplier for all the turnaround spooling scope by a petrochemical plant. This included all site installation (field) materials and fabrication materials. We had to quickly expand our capacity in order to accommodate all of the work. We met all of the client deadlines and more work was added as a result. Ensuring fabricated spools and materials are onsite when required is key to keeping crews productive, and the turnaround on schedule. The client stated that it was their best managed turnaround. Our new fabrication facility is set up to handle maintenance projects from several companies at one time.



# PIPE SPOOL FABRICATION

## SPECIAL PROJECTS

The photo below illustrates a project we completed that included the fabrication of a 36" CSA Z245.11 Grade 550 Class 2-900# steam main tie-in.

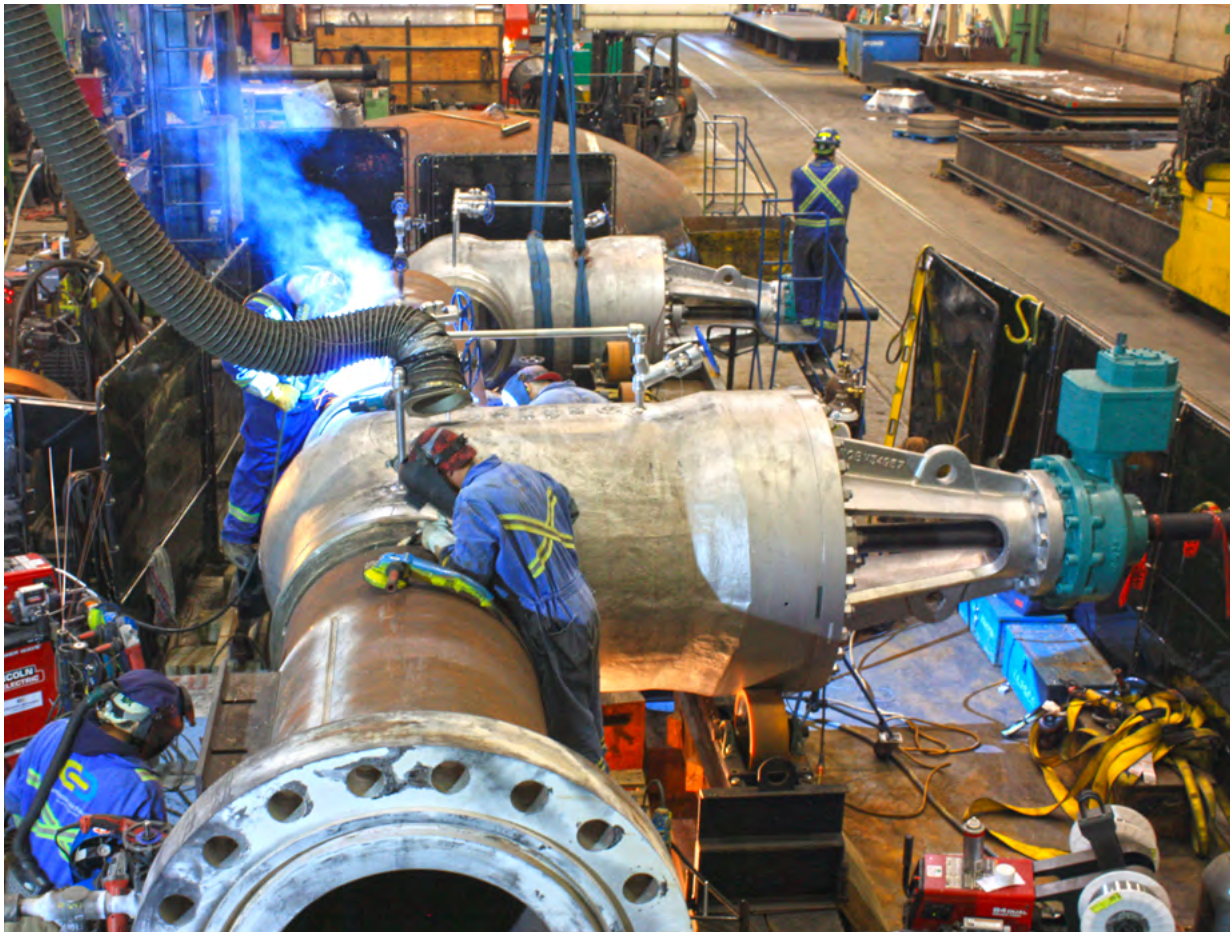

# PIPE SPOOL FABRICATION

## SUBCONTRACTOR VS. SELF-PERFORMED SERVICES CHART

Service	Self Perform (Y/N)	Subcontract (Y/N)	Subcontractor Name	Other Details (Capacity of Service, Limitations, Etc.)
NDE	Yes (All but Radiography)	Yes	TriQuest NDT	Radiography is the only NDE we subcontract out
Hydro-testing	Yes	No		We perform all of our own hydro-testing spools
Paint & Sandblast	No	Yes	Sahara, Park Derochie	Paint vendor chosen based on price and availability
Heat Treatment	Yes (Large PWHTs)	Yes	Brimstone Furnace R&R Stress	EdEx has a large furnace for large PWHT loads. Brimstone has smaller furnaces more efficient for spooling PWHTs R&R provides local heat treatment as well as large oven support
Transportation	Yes	Yes	LG Courier Action Express TripleRandom	We use both internal and third party transportation depending on the needs and requirements of the client

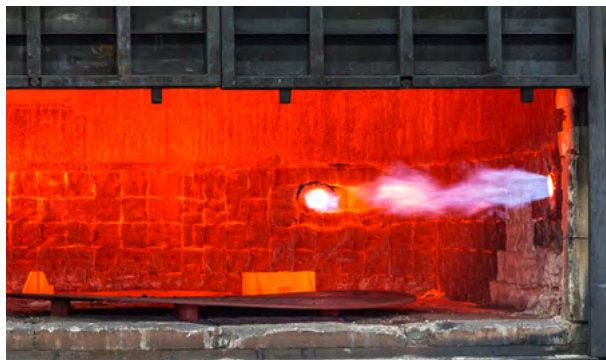

## OTHER SUPPLEMENTARY SERVICES OFFERED AS APPLICABLE TO PIPE FABRICATION

Service	Self Perform (Y/N)	Subcontract (Y/N)	Subcontractor Name	Other Details (Capacity of Service, Limitations, Etc.)
Field Measure	Yes (At Client Site)			EdEx at client site is available to field measure scope to minimize field rework

# PIPE SPOOL FABRICATION

## KEY ATTRIBUTES OF PIPE FABRICATION SHOP (5325 93 STREET)

- Shop Capacity – \$15 Million in sales. Our new facility has allowed us to expand our capacity greatly.
- 41,000 square foot fabrication facility, with three bays and five overhead cranes 6.3 ton – 10 ton range
- Main center bay has two, 10 ton cranes
- Currently set up for 11 welding bays with smoke hogs and jib cranes
- Bays are set up for GTAW, SMAW, GMAW, FCAW, SAW
- Titanium welding capabilities including enclosed welding chamber for small bore piping.
- Heavy power distribution for additional welding / cutting and fabrication throughout the shop
- Sandblaster to handle up to 12" fittings for weld prep if extra cleaning is required
- We have medium, large, and Q. 3 – 6 ton positioners
- Large hydro-testing area
- Band saw cutting table up to 16"
- Mill hogs to prep ends as required
- Vernon Model MPM 5 -0348/40FT - 40 foot cutting bed with pipe range from 3" - 48"
- Five axis head pipe cutter with loading and unloading rack
- Vernon is equipped with plasma for cutting alloys and oxy / acetylene for carbon steel
- 12,000 square foot warehouse for materials storage
- Six acre yard available for storage and assembling modules





# ADDITIONAL SERVICES



## Pressure Vessel Components

Whatever your pressure vessel component requirements, Edmonton Exchanger has your solution. Our steel fabrication division builds a full range of pressure vessel component sizes and thicknesses, and features the most extensive one-stop head forming and shell rolling capabilities in North America. Our steel fabrication operations are supported by our immense inventory of pressure vessel quality carbon steel plate (one of the largest in the world). Large quantities of stainless and chrome moly steel plate are also stocked.

Shop Location: 5545-89 St. NW, Edmonton, Alberta



## Field Services

With over 45 years of experience, Edmonton Exchanger provides on-site plant maintenance services for the petrochemical industry, refineries and fertilizer plants.

Our services range from specialized field machining and controlled bolting to complete turn-key plant and refinery shutdown projects.

Office Location: 5325-93 St. NW, Edmonton, Alberta



## Heat Exchanger Services

We specialize in heat exchanger manufacturing and repair. Our Heat Exchanger Services division stocks a diverse inventory of materials and heat exchanger equipment that allows us to quickly adapt to your project's specialized requirements and specifications.

Upon customer request, we will schedule shop time in preparation for field projects in order to ensure a fast turnaround time for field maintenance work.

Shop Location: 8539 Argyll Rd. NW, Edmonton, Alberta

# ADDITIONAL SERVICES



## Custom Fabrication

Edmonton Exchanger has extensive experience in the custom fabrication and repair of pressure related components. These include replacement vessels and exchangers on a "low volume" and urgent basis, often in support of our field operations. In order to get a plant process back up and running, we can provide expedited fabrication and repair of large and small pressure related components such as pressure vessels, heat exchangers and other items on an "as needed" basis.

Shop Location: 8915-58 Ave. NW, Edmonton, Alberta



## Large-scale Machining Services

Edmonton Exchanger's large-scale machining facility is located in close proximity to our main plant and offers a wide variety of machining services.

It was specially designed to handle large diameter components and boasts equipment that is some of the largest of its kind.

Shop Location: 5606-88 St. NW, Edmonton, Alberta