

# PIPE SPOOL FABRICATION





## EDMONTON EXCHANGER

### COMPANY VALUES

**Excellence:** Consistently offer skillfulness, reliability, quality workmanship and on-time deliveries to our customers.

**Integrity:** Maintain a good reputation in our relations with others by being honest and authentic.

**Communication:** Be accessible, accountable, approachable and humble in our interaction with others.

**Teamwork:** Work together safely to achieve a common goal.

**Efficiency:** Be focused, organized and productive in everything we do.

**Family:** Respect the strength of legacy, tradition, loyalty, community, individual faith and life balance to support future generations.

**Sustainability:** Be persistent, creative and adaptable to achieve financial security as a company in the future.

## CORPORATE OVERVIEW



Tim Gusse, CEO, Gusse Holdings (L), Larry Gusse, CEO, Gusse Family Office (R).

### OVERVIEW

Edmonton Exchanger is a multidivisional organization providing a broad range of products and services to support applications across industries, including oil and gas, petrochemical, and power generation.

The company's divisions include Manufacturing (Pressure Vessel Components), Field Services, Heat Exchanger Services, Custom Fabrication, Pipe Fabrication, and Large-Scale Machining. These divisions work collaboratively to deliver integrated solutions and a comprehensive range of products and services to our customers.

With a workforce of more than 1,000 employees, Edmonton Exchanger is committed to achieving the highest standards of quality and productivity by maintaining a strong focus on health and safety.

### OWNERSHIP

Edmonton Exchanger is a multi-generational, family-owned business founded in 1975 by Henry Gusse. Under Henry's leadership, the company grew steadily over several decades. In 2001, Larry Gusse became President and continued to build on that foundation, guiding Edmonton Exchanger through further growth.

On June 1, 2021, the company marked a formal leadership transition with Tim Gusse assuming the role of President of Edmonton Exchanger and Larry Gusse becoming Chief Executive Officer.

Effective December 2025, Larry Gusse transitioned from CEO of Gusse Holdings, which includes Edmonton Exchanger, to CEO of the Gusse Family Office. In this role, Larry continues to provide long-term strategic oversight, honoring the legacy, stability, and family values that have shaped the company while supporting future generations.

At the same time, Tim Gusse assumed the role of CEO of Gusse Holdings, taking on overall responsibility for Edmonton Exchanger and the broader North American manufacturing businesses. This transition supports continued excellence, operational efficiency, and long-term sustainability as the organization grows.

Ownership of Edmonton Exchanger includes Larry and Adelle Gusse, Tim Gusse, and Natalie Ruhl. As an ownership family, the Gusses are committed to the long-term success of the company and to serving customers and the pressure equipment industry by supporting and leading the Edmonton Exchanger team.



---

# PIPE SPOOL FABRICATION

---

# PIPE SPOOL FABRICATION

Edmonton Exchanger’s pipe fabrication facility is located at our main plant location, and constructs mechanical piping systems to ASME and client specifications.

Key Personnel		
Name	Position	Years with Firm
Steven Bohaychuk	Manager, Estimating / Projects	5
Tony Hallonquist	Pipe Shop Superintendent	16
Katherine Langevin	Quality Control Lead	9
Devin Pearce	Pipe Fabrication Shop Quality Control	10
John Moravec	Pipe Fabrication Shop Foreman	7
Tyler Rose	Pipe Fabrication Shop Foreman	10
Darrel Tranberg	Pipe Fabrication Shop Purchasing	16

## PIPE SPOOL FABRICATION CAPABILITIES

Because we hold over 1,000 weld procedures, we have welded most materials required in Alberta. We can accommodate a wide variety of materials ranging from carbon steel, stainless steel, low alloys and high alloy materials.

### Fabrication certifications:

- Construct, Repair / Alter ASME B31.1 Power Piping and ASME B31.3 Process Piping in the field and shop
- ABSA Construct, Repair / Alter ASME B31.1 Boiler External Piping in the field and shop
- ABSA Manufacture, Repair / Alter Category ‘A’, ‘B’, ‘C’, ‘D’, ‘E’ & ‘H’ Fittings in accordance with CSA B51 in the field and shop
- Canadian Welding Bureau (CWB) certified to CSA Standard W47.1 for structural welding in Division 2, ABSA Welder Testing

Once the project has been welded, our quality control staff who are CWB and CGSB qualified, perform LPI, MPI, Ferrite testing, hardness testing, PMI and UT. Edmonton Exchanger field crews can field measure and verify drawings before fabrication to minimize field work. We can also provide the field support to install the piping system, start the system with operations and then provide continuing maintenance on those systems.

## Manpower

### Permanent Shop Labour:

15-30 (Allocated to Pipe Fabrication Division)

# CRNS

Edmonton Exchanger offers products and services with CRNs. New CRNs can be quoted, designed and built on request. Our in-house engineering and drafting team can handle any other custom requirements with ease and ensure ABSA compliance. We have a close relationship with ABSA because of our history of prudent designs.

Custom Valve modification project requiring a CRN:

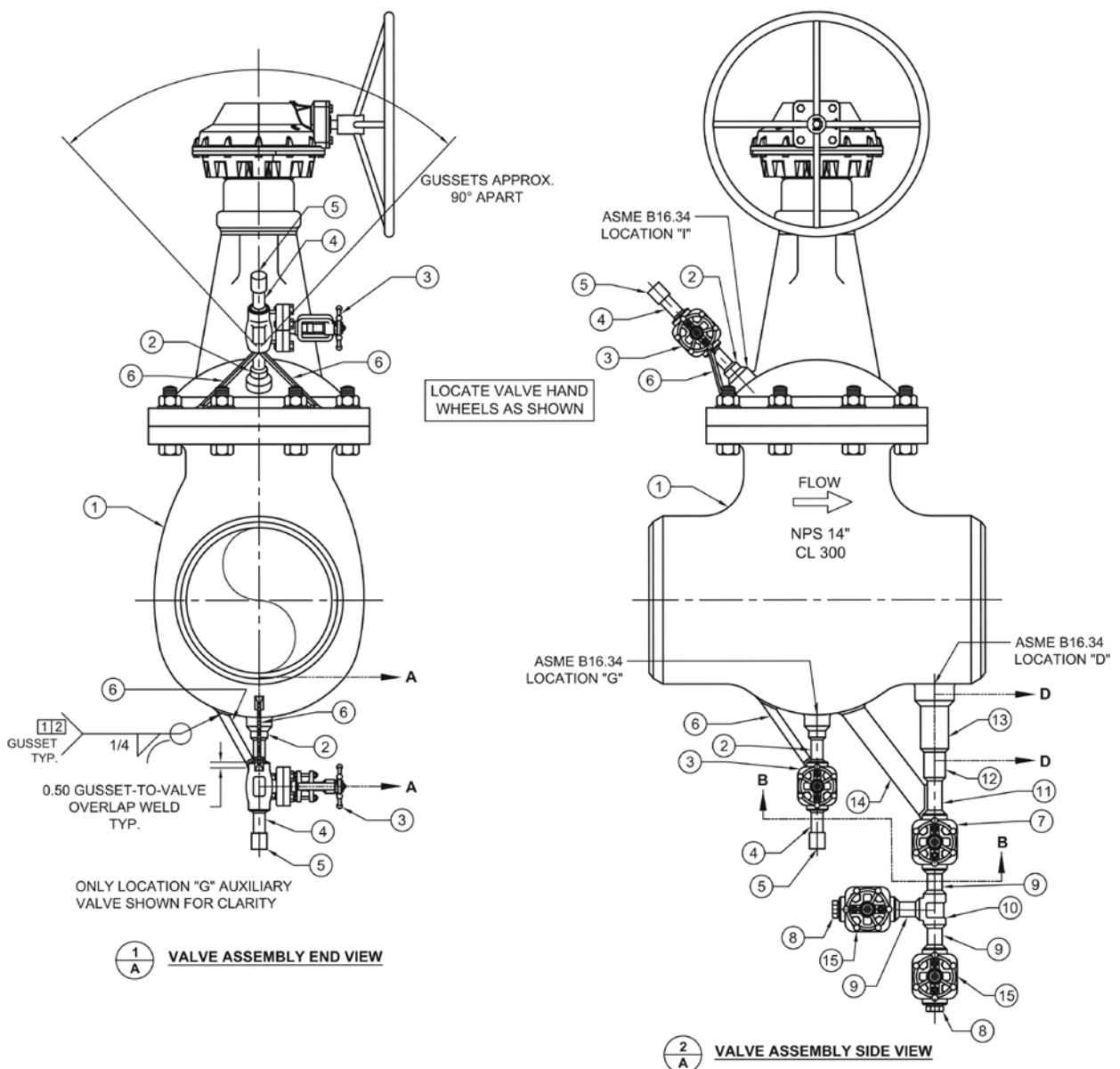

# CRNS

- Edmonton Exchanger has the most comprehensive CRN for valve auxiliary connection modifications in Canada. The CRN covers a wide range of materials, valve sizes, valve ratings, gusseting requirements and the ability to build up valve bosses for under thickness valves.
- The CRN is registered in Alberta, with nation-wide registration being completed in the coming weeks. This CRN covers NPS 2" and larger valves that are rated CL150 to and including CL2500.
- Abbreviated List of Materials covered:
  - Carbon: regular WCB, WCC or low temp LF2, LCB, LCC
  - Chromes: P11, P22, P6, P9
  - Stainless steel: 304, 304H, 316, 317, 321, 321H, 347, 347H
  - Duplex SS: 2205
  - Monel 400, Inco 625 & 825, C22, C276, C2000, Alloy 20

TABLE 8: ASME B16.34 VALVE BODY AUXILIARY CONNECTION BOSS LOCATIONS				
ANGLE VALVE	CHECK VALVE	GATE VALVE	GLOBE VALVE	BALL VALVE
<p>NOTES:</p> <p>1. LOCATIONS FOR VALVE BODY AUXILIARY CONNECTIONS SHALL BE DESIGNATED AS SHOWN</p> <p>2. AUXILIARY CONNECTIONS TO BE DESCRIBED IN ACCORDANCE WITH SPEC.2</p>				

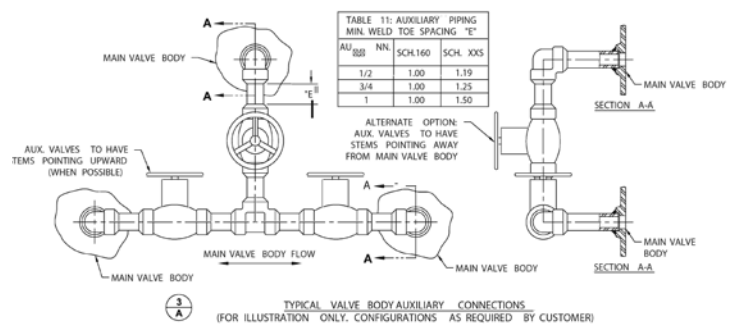
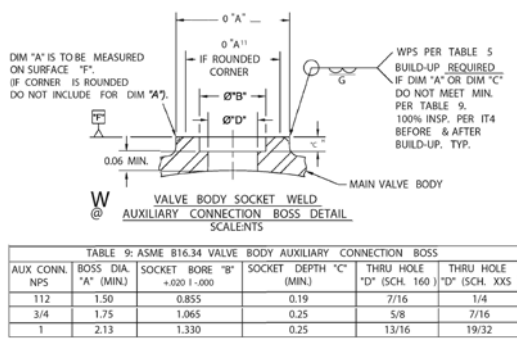

# CRNS

- ABSA CRN Spectacle blinds, zero energy blinds, alky service vented blanks – all items with welded valves / gusseting attached.

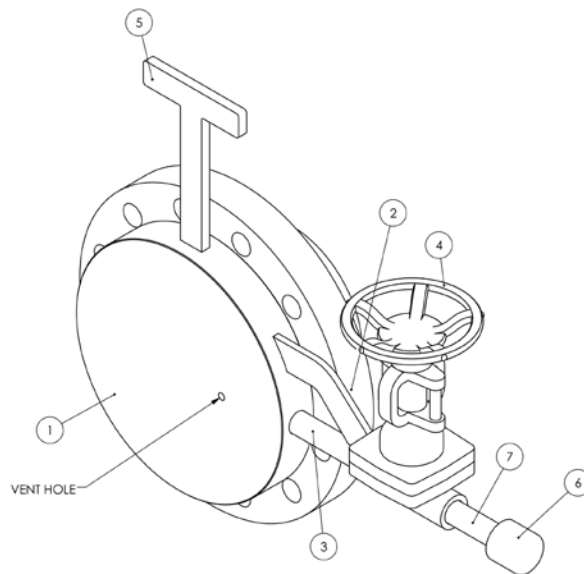

5 VENTED BLANK ASSEMBLY ISOMETRIC VIEW  
A SCALE: DWG

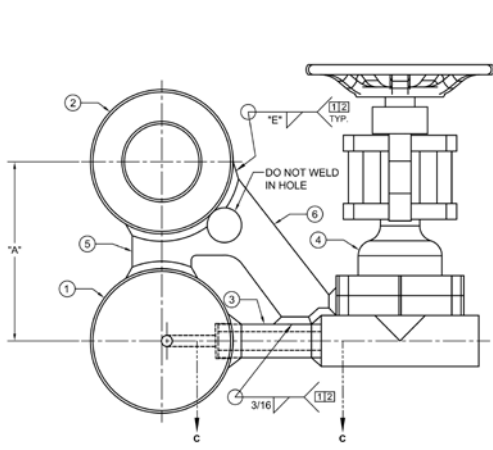

4 NPS 1-1/2" VENTED SPECTACLE  
A BLIND ASSEMBLY DETAIL

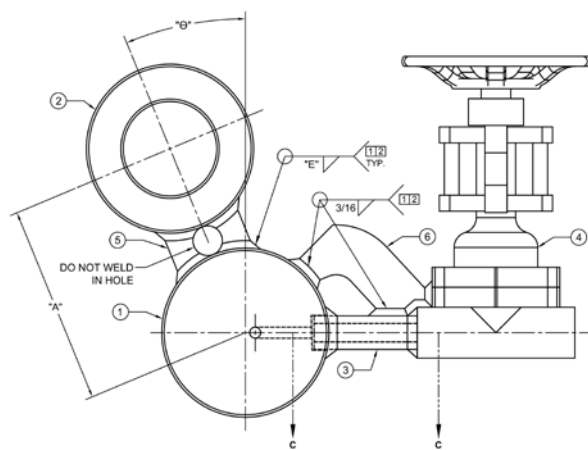

5 NPS 2" VENTED SPECTACLE BLIND  
A ASSEMBLY DETAIL

## OUR PROCESS

We work together with our Field Services team to ensure that what we build is correct to what the field requires. This minimizes / eliminates pipe spool rework. We take the information provided by the field to ensure that the plan can be built in accordance to client weld spacing / specifications, and fits inside the shipping envelope. If there are any issues, we try to identify them before the job has been put into fabrication. This ensures quick project turnaround times for the client.

When we receive a project to bid, we identify the materials that are required. If there are questions or errors on ISOs, we deal with them at the bid stage. This ensures that the work flows as smoothly and as quickly as possible once bids turn into jobs.



Once we are awarded a job, we get the ISO drawings turned into shop fabrication drawings. We provide ISOs marked up with our shop drawing numbers for easy field reference. We submit our shop drawings and the ISO map for field review and mark ups. Edmonton Exchanger reduces field rework by giving the field input into fabrication. The Pipe Fabrication Shop works closely with the Field Services division in determining priority of jobs and spool deliveries.

We have software which allows us to draft the fabrication drawings with Welder IDs, NDE performed, heat numbers of parts, weld procedures as well as to make any drawings changes required by the client. Drafting in-house enables us to quickly make drawing revisions with minimal downtime as the project scope changes. This software tracks material inventory and NDE percentages. All spools are provided with two plastic tags with the drawing information. For easy identification, these tags display the fabrication drawing number, client isometric, and project name.



We order materials from reputable suppliers in accordance with client specifications and approved manufacturer lists. All fabricated components undergo a thorough Quality Control inspection to ensure compliance to the applicable ASME code to which it has been constructed and all Jurisdictional requirements have been met. Our stringent QC program which also includes shop checking of all orientations and dimensions prior to shipment. All flanges are covered with plastic or wood flange covers prior to shipping.

## MATERIALS MANAGEMENT

We are a maintenance spool fabrication provider. We are accustomed to delivering projects to tight deadlines. In spring 2018, we completed over 100 separate turnaround piping jobs in time for a spring turnaround. Supplying both the fabrication materials and field materials for all jobs. Jobs ranged in materials from low temperature carbon steel, to chrome and stainless steel. Over 20 different material / service classes.

We have sufficient storage space for both inventory materials for new fabrication and completed spools. Our North warehouse can be utilized as well in addition to our six acre yard. We have a comprehensive material management and receiving system that ensures the correct materials are used. We work with a wide range of materials including carbon steel, stainless, chrome, and high/low alloys.



## WELD PROCEDURES

Edmonton Exchanger has over 1,000 current weld procedures.

## SCOPE OF WORK AND ANNUAL DEMAND

The EDEX Pipe Fabrication Shop is familiar with maintenance piping projects for numerous clients.

In early 2017, our Pipe Fabrication Shop was sole sourced as the piping supplier for all the turnaround spooling scope by a petrochemical plant. This included all site installation (field) materials and fabrication materials. We had to quickly expand our capacity in order to accommodate all of the work. We met all of the client deadlines and more work was added as a result. Ensuring fabricated spools and materials are onsite when required is key to keeping crews productive, and the turnaround on schedule. The client stated that it was their best managed turnaround. Our new fabrication facility is set up to handle maintenance projects from several companies at one time.

# TIP TIG WELDING

Edmonton Exchanger employs advanced TIP TIG welding technology in its Pipe Spool Fabrication shop, supported by Q.1 overhead cranes with capacities of 6.3 tons and 10 tons. TIP TIG welding is a form of gas tungsten arc welding (GTAW) that uses a wire feeder system to agitate the filler wire. This agitation enhances the fluidity of the molten weld pool and facilitates the release of gases, thereby reducing the risk of porosity and inclusions.

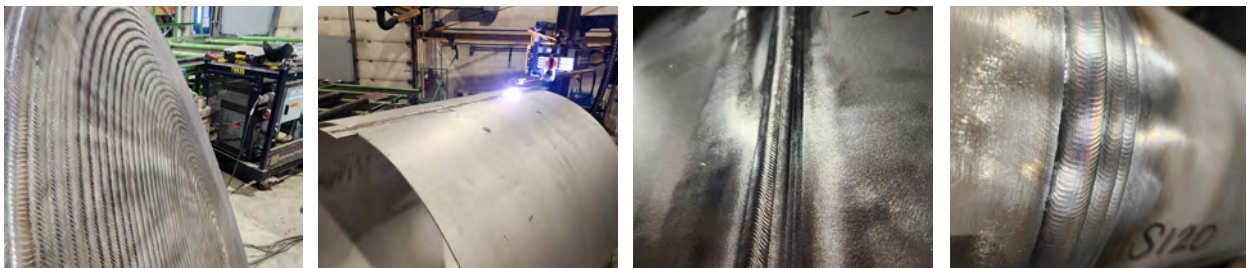

## OVERLAY WELDING CAPABILITIES

- Inside of pipe ranging from 8" to 60", maximum 10' in length
- Flange Face and ID (8" min ID, no min for Flange Face)
- Eccentric and Concentric reducers, min 8" ID
- Straight and Reducing Tees, min 8" ID
- Tube sheets. 5" min OD, 60" max OD. Capable of larger OD if a new positioner is purchased.

### Buttweld Capabilities

- Carbon steel
- 3XX stainless steel
- Thickness ranging from 0.25" to 1.124" (C.S. and S.S.)
- 8' 5" boom extension for long seams
- 11' torch head to ground clearance

### Current Weld Procedures

- WPS-1003 (P1 Material – ERNiCr Mo-14, F43 Overlay)
- WPS-1166 (P8 Material – ER308L, F6 Overlay)
- WPS-1167 (P1 Material – ER3XX, F6 Overlay)
- WPS-1168 (P8 Material – ER16-8-2, F6 Overlay)
- WPS-1238 (P8 to P8 Material – ER3XX)
- WPS-1248 (P1 to P1 Material – ER70S-2)

## SPECIAL PROJECTS

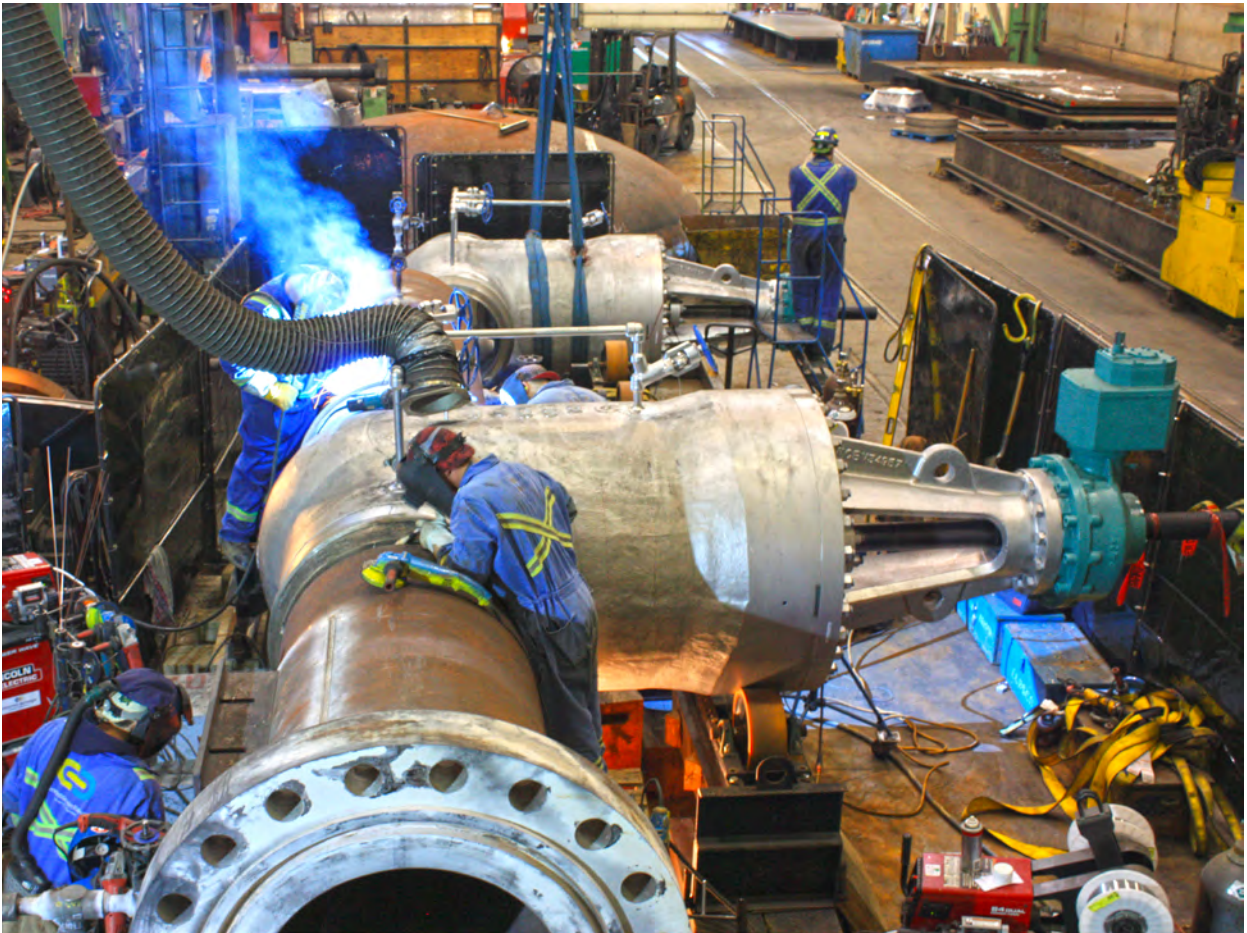

The photo above illustrates a project we completed that included the fabrication of a 36" CSA Z245.11 Grade 550 Class 2- 900# steam main tie-in.

# PIPE FABRICATION SERVICES

## SUBCONTRACTOR VS. SELF-PERFORMED SERVICES CHART

Service	Self Perform (Y/N)	Subcontract (Y/N)	Subcontractor Name	Other Details (Capacity of Service, Limitations, Etc.)
NDE	Yes (All but Radiography)	Yes	TriQuest NDT	Radiography is the only NDE we subcontract out
Hydro-testing	Yes	No		We perform all of our own hydro-testing spools
Paint & Sandblast	No	Yes	Sahara, Park Derochie	Paint vendor chosen based on price and availability
Heat Treatment	Yes (Large PWHTs)	Yes	Brimstone Furnace R&R Stress	EdEx has a large furnace for large PWHT loads. Brimstone has smaller furnaces more efficient for spooling PWHTs R&R provides local heat treatment as well as large oven support
Transportation	Yes	Yes	LG Courier Action Express TripleRandom	We use both internal and third party transportation depending on the needs and requirements of the client

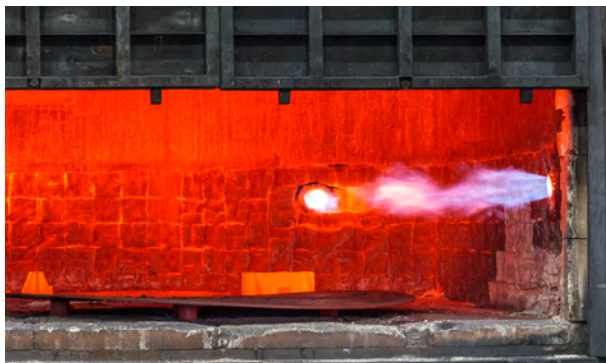

## OTHER SUPPLEMENTARY SERVICES OFFERED

Service	Self Perform (Y/N)	Subcontract (Y/N)	Subcontractor Name	Other Details (Capacity of Service, Limitations, Etc.)
Field Measure	Yes (At Client Site)			EdEx at client site is available to field measure scope to minimize field rework

## PIPE FABRICATION FACILITIES



### Key Attributes of Pipe Fabrication Shop (5325-93 Street)

- Shop Capacity – \$15 Million in sales. Our new facility has allowed us to expand our capacity greatly.
- 41,000 square foot fabrication facility, with three bays and five overhead cranes 6.3 ton
- 10 ton range
- Main center bay has two, 10 ton cranes
- Currently set up for 11 welding bays with smoke hogs and jib cranes
- Bays are set up for GTAW, SMAW, GMAW, FCAW, SAW
- Titanium welding capabilities including enclosed welding chamber for small bore piping.
- Heavy power distribution for additional welding / cutting and fabrication throughout the shop
- Sandblaster to handle up to 12" fittings for weld prep if extra cleaning is required
- We have medium, large, and Q. 3 – 6 ton positioners
- Large hydro-testing area
- Band saw cutting table up to 16"
- Mill hogs to prep ends as required
- Vernon Model MPM 5 -0348/40FT - 40 foot cutting bed with pipe range from 3" - 48"
- Five axis head pipe cutter with loading and unloading rack
- Vernon is equipped with plasma for cutting alloys and oxy / acetylene for carbon steel
- 12,000 square foot warehouse for materials storage
- Six acre yard available for storage and assembling modules

# ADDITIONAL SERVICES FROM EDEX

## Comprehensive Solutions for All Your Requirements

EDEX operates through six specialized divisions. Each division is dedicated to delivering industry-leading solutions tailored to its clients' unique requirements. This multifaceted structure allows us to provide comprehensive services under one roof, a one-stop shop.



### PRESSURE VESSEL COMPONENTS

Feature the most extensive one-stop head forming and shell rolling capabilities in North America.



### FIELD SERVICES

On-site plant maintenance services for the petrochemical industry, refineries and fertilizer plants.



### HEAT EXCHANGER SERVICES

Heat exchanger manufacturing and repair services. Fully supported by a vast inventory of heat exchanger specific materials and equipment.



### CUSTOM FABRICATION

Custom fabrication and repair of pressure related components.



### LARGE-SCALE MACHINING

Specializing in large-diameter components as well as CNC tube sheet drilling applications.



### PIPE SPOOL FABRICATION

Constructs mechanical piping systems to ASME and client specifications, and holds over 1,000 weld procedures.



## EDEX: YOUR TRUSTED SOURCE FOR MANUFACTURING AND MAINTENANCE PROJECTS

Here are just some of the reasons we're the project partners you can count on:

- ✓ Size and experience: founded in 1975 and over 1,000 employees-strong
- ✓ A commitment to quality and safety excellence since day-one
- ✓ Specialists in the manufacturing of large-scale pressure vessel components
- ✓ Steel forming capacities are some of the largest of their kind
- ✓ One of the largest inventories of pressure vessel quality steel plate in the world
- ✓ The most extensive one-stop pressure vessel head forming and shell rolling capabilities in North America
- ✓ Wide range of machining services, and specialists in large-scale milling and tube sheet drilling for heat exchanger applications
- ✓ On-site plant maintenance services for the petrochemical industry, refineries and fertilizer plants
- ✓ Services range from specialized field machining and controlled bolting, to complete turn-key petrochemical plant and refinery shutdown projects, to emergency maintenance



**EDMONTON  
EXCHANGER**

## CONTACT US

### **Head Office / Main Plant**

Edmonton Exchanger  
5545-89 Street, NW  
Edmonton, Alberta, Canada T6E 5W9

### **Field Services Office**

5325-93 Street, NW  
Edmonton, Alberta, Canada

### **Engineering / Estimating Office**

5606-88 Street, NW  
Edmonton, Alberta, Canada

### **Accounting Office**

5614-88 Street, NW  
Edmonton, Alberta, Canada

### **Heat Exchanger Services Shop**

8539 Argyll Road  
Edmonton, Alberta, Canada

### **Pipe Fabrication Shop**

5325-93 Street, NW  
Edmonton, Alberta, Canada

### **Custom Fabrication Shop**

8915-58 Avenue, NW  
Edmonton, Alberta, Canada

### **E-Mail:**

Request a Quote: [equote@edmontonexchanger.com](mailto:equote@edmontonexchanger.com)

General Inquiries: [sales@edmontonexchanger.com](mailto:sales@edmontonexchanger.com)

Submit a Resume: [hr@edmontonexchanger.com](mailto:hr@edmontonexchanger.com)

### **Telephone:**

780-468-6722 (Main Line)

Toll Free (Alberta): 1-888-343-4365